

# TriScroll 600

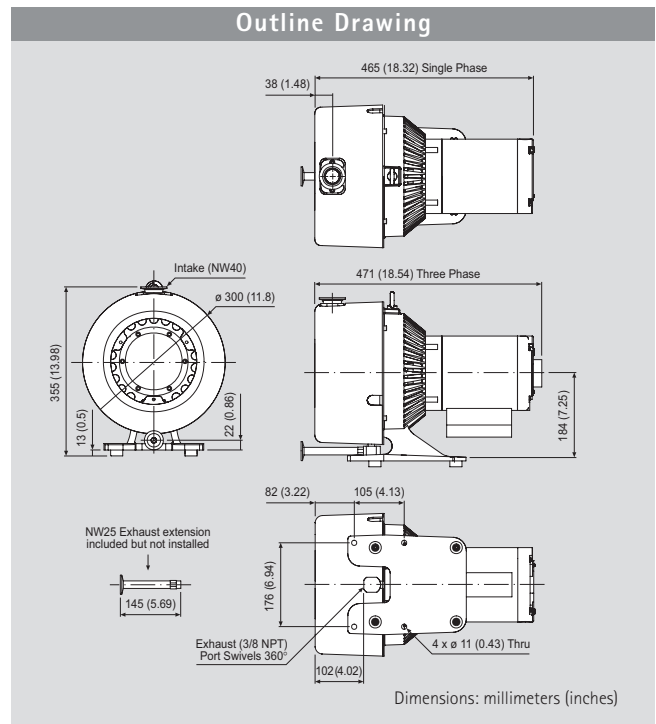

## Technical Specifications

Peak pumping speed	50 Hz: 420 l/m, 25.2 m <sup>3</sup> /hr (14.8 cfm); 60 Hz: 500 l/m 30 m <sup>3</sup> /hr (17.7 cfm)
Media	Clean atmospheric gases. Not suitable for toxic, corrosive, explosive, or particulate forming gases.
Ultimate pressure	9.3 x 10 <sup>-3</sup> mbar (7.0 x 10 <sup>-3</sup> Torr)
Maximum inlet pressure	1.0 atmosphere (0 psig)
Maximum outlet pressure	1.1 atmosphere (1.5 psig)
Inlet Connection	NW40
Exhaust Connection	3/8" Female NPT with swivel (NW25 adapter provided)
Gas ballast	1/4" Female NPT (40 micron sintered filter provided)
Ambient operating temperature	5 °C to 40 °C (41 °F to 104 °F)
Storage temperature	-20 °C to 60 °C (-4 °F to 140 °F)
Motor rating (1 phase)	1.0 HP (0.76 kW)
Operating Voltages	Single phase models: 50-60 Hz/100-115:200-230 VAC Three phase models: 50 Hz/200-230:380-415 VAC; 60 Hz/200-230:460 VAC
Motor thermal protection	Type U automatic
Operating speed	50 Hz: 1425 RPM; 60 Hz: 1725 RPM
Cooling system	Air-cooled
Weight	Pump only: 32 kg (70 lbs) Shipping weight: 40 kg (87 lbs)
Noise level (per ISO 11201)	68 dB(A)
Vibration level (per ISO 10816-1)	6.3 mm/sec
Certification	CE marked Motor: UL, CSA

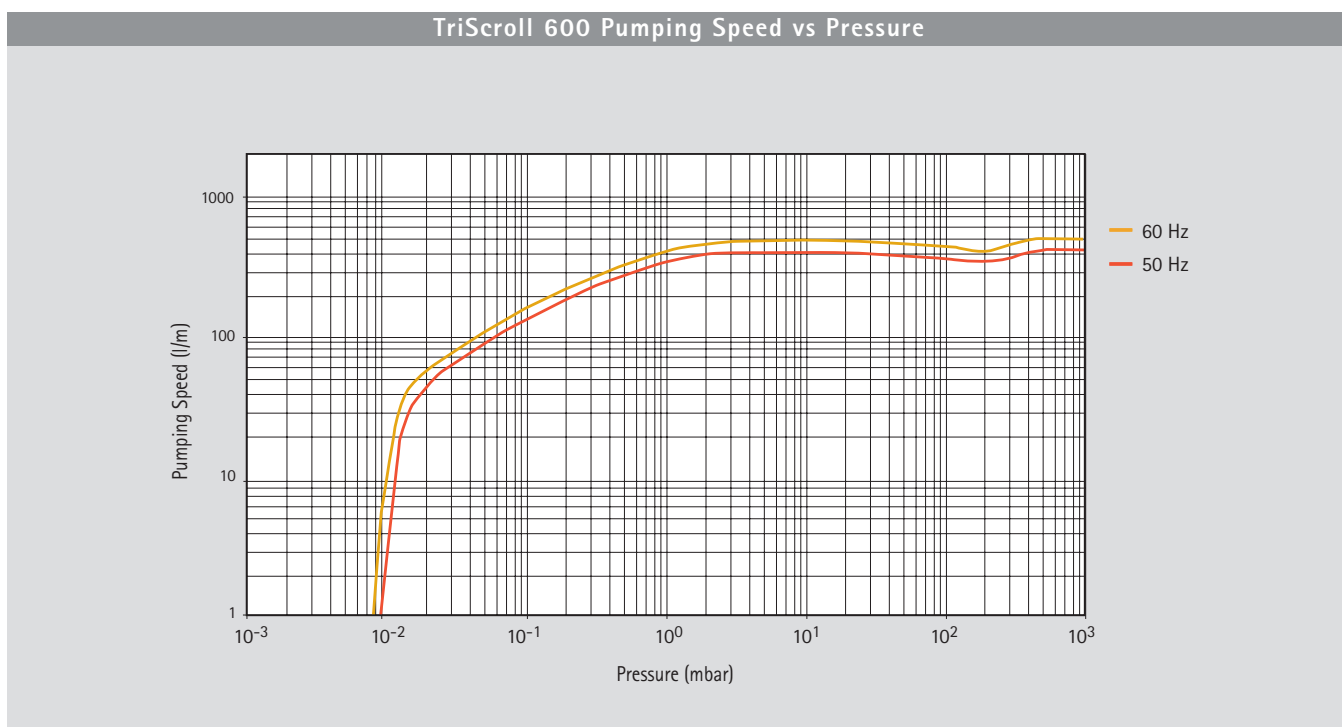

**Ordering Information**

Description	Part Number
TriScroll 600 dry scroll primary pump, single phase motor	PTS06001UNIV
TriScroll 600 dry scroll primary pump, single phase motor, Euro cord	PTS06001UNIVEU
TriScroll 600 dry scroll primary pump, single phase motor, UK cord	PTS06001UNIVUK
TriScroll 600 dry scroll primary pump, three phase motor	PTS06003UNIV
TriScroll 600, single phase, with Vacuum Pump Isolation Valve (VPI), 120 VAC	PTS06001UVPI*
TriScroll 600, single phase, with VPI, 220 VAC, EU power cord	PTS06001UVPIEU
TriScroll 600, three phase, with VPI, 200 VAC	PTS06003200VPI
TriScroll 600, three phase, with VPI, 230 VAC	PTS06003230VPI
TriScroll 600, three phase, with VPI, 380/415 VAC	PTS06003380415VPI
TriScroll 600, three phase, with VPI, 460 VAC	PTS06003460VPI

**Products for maintaining your TriScroll pump**

Maintenance kit	PTSS0600MK
Maintenance tool kit	PTSS0600TK
Replacement tip seal kit	PTSS0600TS
TS300/600 tip seal tool kit	PTSTSTKIT

**Accessories**

Purge kit, TriScroll	PTSPURGEKIT
Three phase cable kit	S4789001
TS600 exhaust extension	S4807001
TS600 exhaust filter kit	PTS600EXFIL

\*Contact Varian for other voltages.